

Assembly Instructions

Before you begin, please make sure all parts and proper quantities are included. (See Part Identifier Key) Any parts damaged during shipment must be reported within 24 hours of receipt. To report information regarding damages or if you have any questions, please call 800.242.2303.

Step 1:

- Place the TORO top face down on a protected flat surface.

Step 2:

- Place TORO frame down on top of the TORO top and align with pre-drilled pilot holes.
- If assembling an **Epoxy top**, see Epoxy TORO Table Assembly Instructions.
- If assembling a **2 piece Hardwood top**, see Hardwood TORO Table Assembly Instructions.

Step 3:

- Using a # S2 square bit, secure frame to table top with #10 x 3/4" square pan screws. One screw per tab.

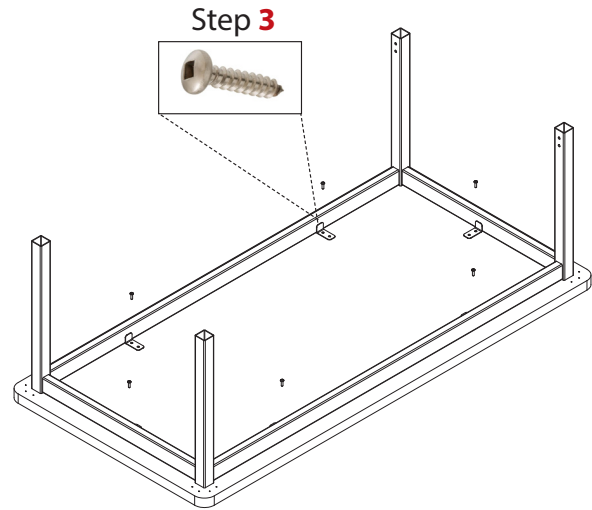

Step 4:

- Locate TORO inserts. Remove M6 screws and #12 star washers from the insert using a 4mm hex wrench.

Step 5:

- Place insert into TORO frame and once desired height is attained, place #12 star washer and M6 screw through the hole and tighten with a 4mm hex wrench. Repeat with the 2nd star washer and M6 screw.
- Repeat Step 5 for the remaining inserts.

Step 6:

- With someone's help, turn table upright.

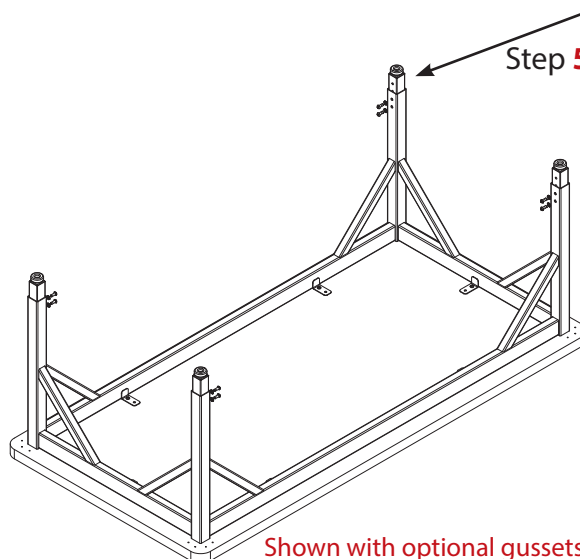
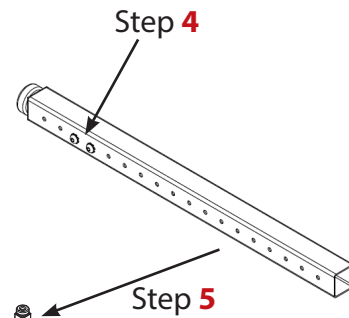

Tools Required

- 4mm Hex Wrench
- Screw Gun
- # S2 Square Bit

Part Identifier Key

Part #	Description	Qty.	
0408231	#10 x 3/4" Square pan screws <i>(Used to attach frame to top)</i>	10 (Included in Hardware Pack located in leg box. May need less depending on size and work service)	

3" Heavy Duty Caster Hardware Pack (04066968) Used only with 2" adj. legs (-ALR)

Part #	Description	Qty.	
04067460	1/4" Star washers	4 per set	
04067064	M6 1x18 screws <i>(Used in leg insert to prevent bending of the leg insert)</i>	4 per set (Included in Hardware Pack located in leg box as standard. Discard if casters are not installed.)	

3" Heavy Duty Caster Hardware Pack (0402020) Used only with 1.5" adj. legs (-ADJ)

04067460	1/4" Star washers	4 per set	
0401259	M6 1x14 screws <i>(Used in leg insert to prevent bending of the leg insert)</i>	4 per set (Included in Hardware Pack located in leg box as standard. Discard if casters are not installed.)	

TORO Leg Options

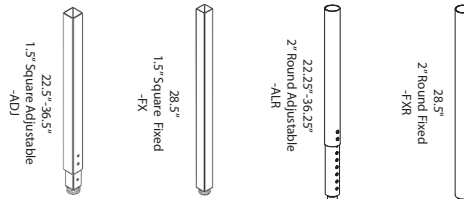

Assembly Instructions

Before you begin, please make sure all parts and proper quantities are included. (See Part Identifier Key) Any parts damaged during shipment must be reported within 24 hours of receipt. To report information regarding damages or if you have any questions, please call 800.242.2303.

Step 1:

- Remove Nylon glide from leg by rotating counterclockwise until glide is free.

Step 2:

- Place stem of optional footing into the hole on the leg. Rotate clockwise until fully inserted into leg.
- Casters are **NOT** to be used as a leveling device.

Step 3:

- Tighten with a 14mm open-ended wrench. (only with the Dual wheel soft tread locking caster.)

Step 4:

- Repeat for each caster or glide.

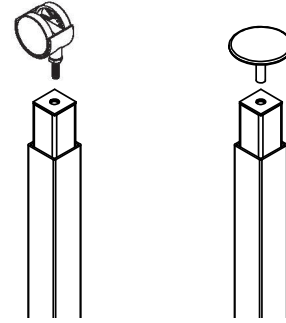





Installing casters on tables with epoxy resin tops will void the Epoxy warranty.

Tools Required

- 14mm open-ended wrench

Part Identifier Key

Part #	Description	Qty.	
040164	1 3/8" Dia. Grand Hank glide, 3/8"-16 x 1"	1 per leg	
04067920	1.5" Soft Touch glide	1 per leg	
33056S	1.25" Steel glide	1 per leg	
04067540	Dual wheel soft tread locking casters (N/A on epoxy resin tops)	1 per leg	

TORO Leg Options

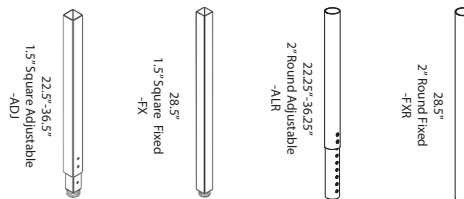

Assembly Instructions

Before you begin, please make sure all parts and proper quantities are included. (See Part Identifier Key) Any parts damaged during shipment must be reported within 24 hours of receipt. To report information regarding damages or if you have any questions, please call 800.242.2303.

Step 1:

- Before placing caster in the bottom of the leg, lock the caster by pushing down on the brake lever.

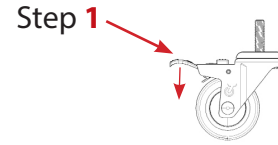

Step 2:

- Twist the stem of the caster into the hole on the bottom of the leg. Applying thread locking adhesive can help prevent unexpected loosening of the caster.

Step 3:

- Use 3/4" wrench to tighten 3/4" nut on stem of caster.

Step 4:

- If using adj. legs, insert star washer and M6 screw in hole closest to the caster and tighten with 4mm hex wrench. **DO NOT OVER TIGHTEN.**
- If using a **FIXED leg**, you will **NOT** need to use a star washer and M6 screw.

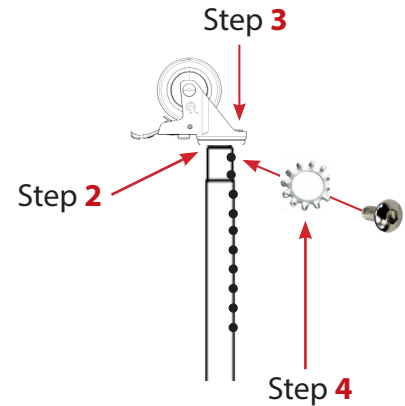

Step 5:

- Repeat for remaining casters.

Casters are **NOT** to be used as a leveling device.

Tools Required

- 3/4" Wrench
- 4mm Hex Wrench
- Thread Locking Adhesive (optional)

Installing casters on tables with epoxy resin tops will void the Epoxy warranty.

Part Identifier Key

Part #	Description	Qty.	
0400993	3" heavy duty locking casters	1 per leg	

3" Heavy Duty Caster Hardware Pack (04066968) Used only with 2" adj. legs (-ALR)

Part #	Description	Qty.	
04067460	1/4" Star washers	4 per set	 (Included in Hardware Pack located in leg box as standard. Discard if casters are not installed.)
04067064	M6 1x18 screws	4 per set	

3" Heavy Duty Caster Hardware Pack (0402020) Used only with 1.5" adj. legs (-ADJ)

Part #	Description	Qty.	
04067460	1/4" Star washers	4 per set	 (Included in Hardware Pack located in leg box as standard. Discard if casters are not installed.)
0401259	M6 1x14 screws	4 per set	