

Assembly Instructions*

Before you begin, please make sure all parts and proper quantities are included. Any parts damaged during shipment must be reported within 24 hours of receipt. To report information regarding damages or if you have any questions, please call 800.242.2303.

Step 1.

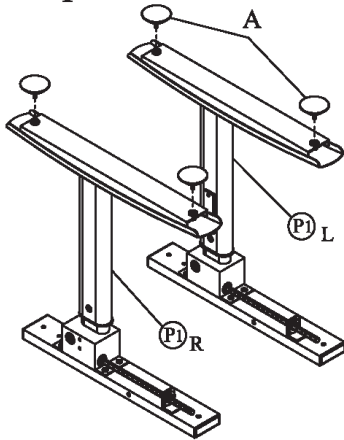

Step 2.

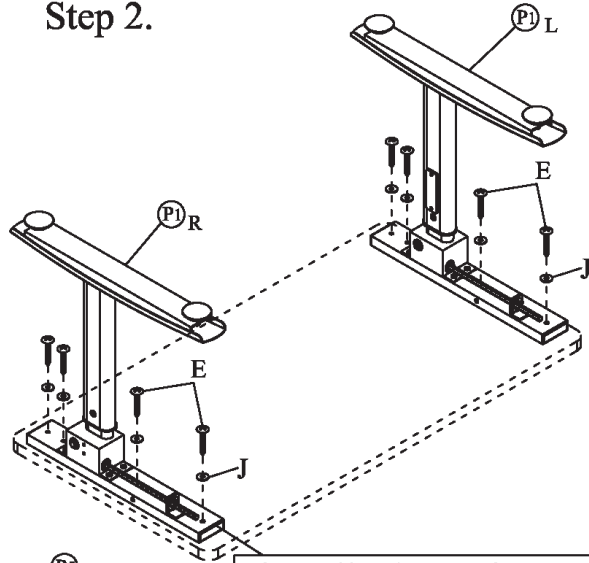

Step 3.

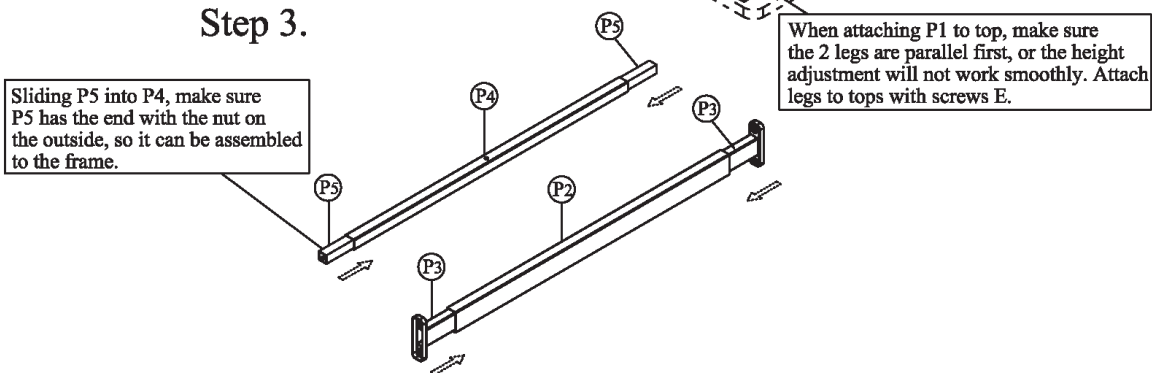

Installing Top to Base

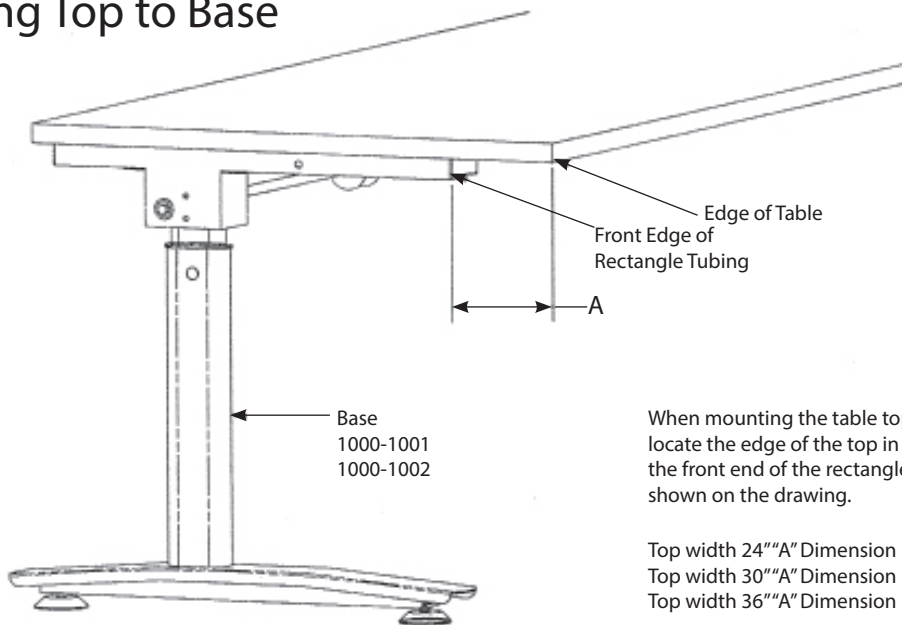

When mounting the table top to the base, locate the edge of the top in relation to the front end of the rectangle tube as shown on the drawing.

Top width 24" "A" Dimension is 5/8"
Top width 30" "A" Dimension is 3"
Top width 36" "A" Dimension is 3 1/4"

*These Installation Instructions will also be located in the box of parts.

Step 4.

When placing P6 into the gear box make sure it is pushed all the way in, then use Open End Wrench I, to tighten the hex nut. Do not over tighten.

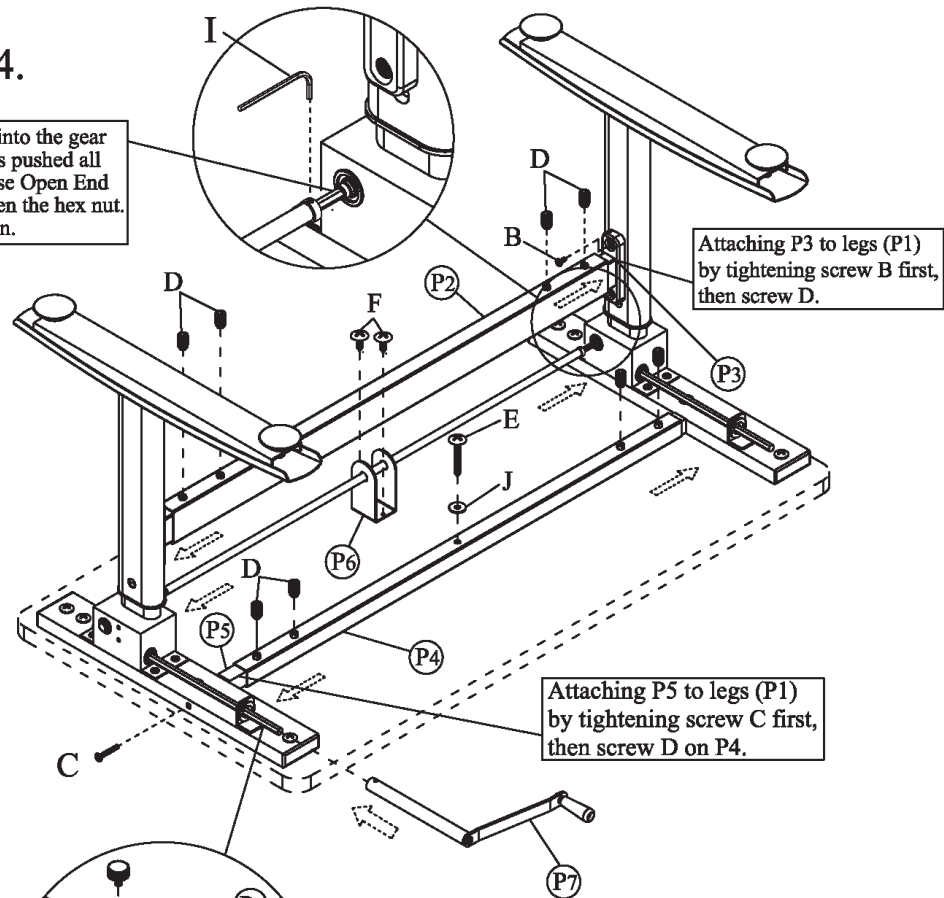

Step 5.

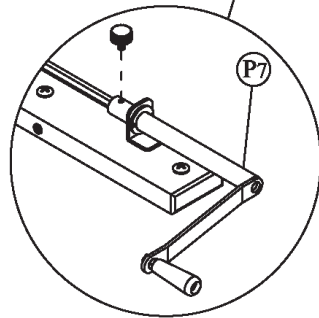

Step 6.

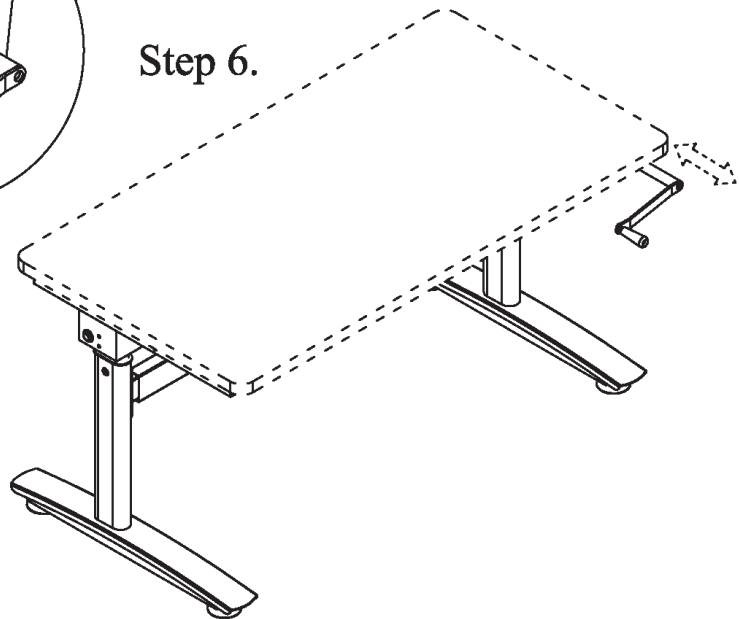

Part Identifier Key

